

Milk Transportation Tanks

Keep your milk safe



MILK TRANSPORTATION

Milkplan[®]
FARMING TECHNOLOGIES

MP CoolMilk Transfer

Electricity or Generator-powered Cooling (CTT500 - 2.000lt)

The milk transportation tank MP CoolMilk Transfer is a smart solution for reliable and efficient milk transportation and cooling. Available in 4 models, with a capacity that ranges between 500 and 2,000lt.

Technical specifications



- Highly-durable, robust construction.
- Smooth inner walls, rounded corners, perfectly polished welds.
- Oval shape for low gravity center maintenance for better vehicle balance during transportation.
- Made of stainless steel AISI 304 (DIN 1.4301).
- Thermal insulation made of environmentally friendly and high-density polyurethane foam.
- Specially designed evaporator for effective milk cooling, highly durable due to its laser welding.
- Pressure equalization system made of stainless steel.
- Stainless steel outlet butterfly valve DN50, SMS51 or Triclamp.
- Integrated programmable agitation system.
- Agitation shaft mounded in two points (on the tank's top and bottom).
- Shockproof, high-performance cooling unit (Scroll technology compressor) for 2 or 4 milkings.
- Dixell electronic controller for milk cooling and agitation as well as milk temperature indication.

Washing and disinfection system

- Washing system made of high-quality materials in order to prevent any possibility of corrosion even by the most powerful disinfectants.
- Powerful water pump that ensures continuous recirculation, constant water flow and proper spraying pressure.
- Independent peristaltic pumps which provide the necessary quantity of liquid disinfectants.
- Efficient tank washing with spray system and special rotating blades.
- PLC washing controller with fully adjustable parameters, responsive to software updates.



Operating features

- Easy to use, complete control over all functions.
- Reliable performance and long life span.
- Easy cleaning.
- Complete sealing for the milk's safe transportation.
- Effective cooling in accordance with international standards.



Plus

- Optional generator installation for milk cooling during transportation.
- Powerful milk pump 380V, 230V, or 12V with special stainless steel base.
- Galvanized iron trailer with lights, thrust and parking brakes, suspensions and a retractable tire.
- Washing system mounted directly on the tank or standalone on a wall (in this case it can be used for more than one tanks).

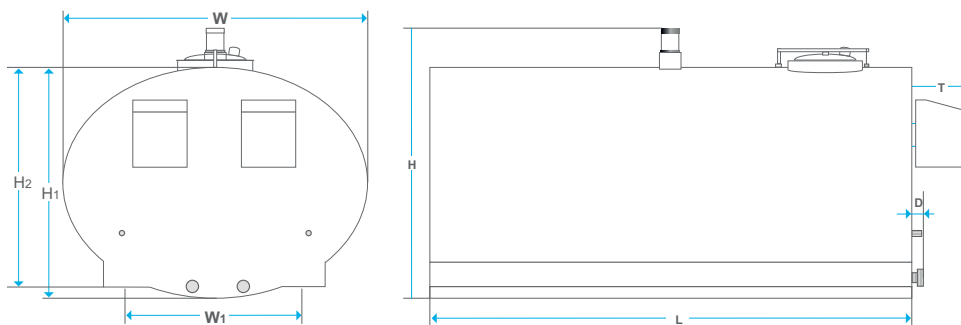

Type	Max. capacity	W	W1	H1	H2	H	L
CTT 500E	530	990	990	800	765	1055	1250
CTT 1000E	1050	1320	990	1080	1030	1320	1250
CTT 1500E	1580	1320	990	1080	1030	1320	1830
CTT 2000E	2100	1320	990	1080	1030	1320	2400
	lt	mm	mm	mm	mm	mm	mm

MP Milk Transfer (TT500 - 4.000lt)

MP Milk Transfer milk transportation tanks are specially insulated tanks made of stainless steel, which ensure a steady temperature for a time period of 8 to 12 hours. Available in 12 models with a capacity that ranges between 500 and 4,000lt.



Washing and disinfection system

- Washing system made of high-quality materials in order to prevent any possibility of corrosion even by the most powerful disinfectants.
- Powerful water pump that ensures continuous recirculation, constant water flow and proper spraying pressure.
- Independent peristaltic pumps which provide the necessary quantity of liquid disinfectants.
- PLC washing controller with fully adjustable parameters, responsive to software updates.



Technical specifications



- Highly-durable, robust construction.
- Smooth inner walls, rounded corners, perfectly polished welds.
- Oval shape for low gravity center maintenance for better vehicle balance during transportation.
- Thermal insulation made of environmentally friendly and high-density polyurethane foam.
- Made of stainless steel AISI 304 (DIN 1.4301).
- Pressure equalization system made of stainless steel.
- Protective milk outlet cover made of PVC with a chain holding it in place.
- AISI 304 stainless steel manhole edge (D400mm), raised to ensure safe milk transportation.
- Optional division of the interior in more than one compartment to allow multiple shipments from different producers.
- Separate stainless steel outlet butterfly valves for each compartment DN50, SMS51 or Triclamp.
- Sprayball system for each compartment.

MP CoolMilk Transfer

Cooling with cold water (CTT500 - 2.000lt)

MP CoolMilk Transfer is also available in another version which cools milk using cold water at the temperature of 1°C. It is the ideal solution for areas where cold water is abundant in the environment. Alternatively, this tank can be used with ice-banks. Available in 4 models with a capacity that ranges between 500 and 2,000lt.

Washing and disinfection system

- Washing system made of high-quality materials in order to prevent any possibility of corrosion even by the most powerful disinfectants.
- Powerful water pump that ensures continuous recirculation, constant water flow and proper spraying pressure.
- Independent peristaltic pumps which provide the necessary quantity of liquid disinfectants.
- Efficient tank washing with spray system and special rotating blades.
- PLC washing controller with fully adjustable parameters, responsive to software updates.



Operating features

- Easy to use, complete control over all functions.
- Reliable performance and long life span.
- Significant energy savings.
- Easy cleaning.
- Complete sealing for the milk's safe transportation.
- Effective milk cooling with continuous circulation and steady flow.



Technical specifications

- Highly-durable, robust construction.
- Smooth inner walls, rounded angles, perfectly polished welds.
- Oval shape for low gravity center maintenance for better vehicle balance during transportation.
- Made of stainless steel AISI 304 (DIN 1.4301).
- Stainless steel pressure equalization system.
- Integrated, programmable agitation system.
- Agitation shaft mounded in two points (on the tank's top and bottom).
- Stainless steel outlet butterfly valve DN50, SMS51 or Triclamp.
- Specially designed, stainless steel water filter.
- Thermal insulation made of environmentally friendly and high-density polyurethane foam.
- Dixell electronic controller for milk cooling and agitation as well as milk temperature indication.



Plus

- Washing system mounted directly on the tank or standalone on a wall (in this case it can be used for more than one tanks).
- Galvanized iron trailer with lights, thrust and parking brakes, suspensions and a retractable tire.
- Tank interior which optionally may be divided in two parts, one of which may have an evaporator.
- Powerful milk pump of 230V or 12V with special stainless steel base.
- Stainless steel control panel for the temperature and the milk pump control.

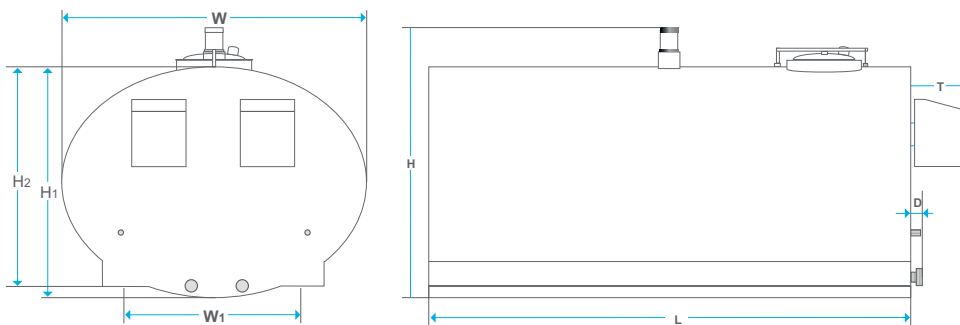

Type	Max. capacity	W	W1	H1	H2	H	L
CTT 500E	530	990	990	800	765	1055	1250
CTT 1000E	1050	1320	990	1080	1030	1320	1250
CTT 1500E	1580	1320	990	1080	1030	1320	1830
CTT 2000E	2100	1320	990	1080	1030	1320	2400
	lit	mm	mm	mm	mm	mm	mm



3rd km. Provincial road Lagada - Kolchiko
572 00 Lagadas, Thessaloniki Greece

T/F +30 23940 20400
E sales@milkplan.com

www.milkplan.com